

QUIKFLEX[®] 200

BOTTLE PACKAGING SYSTEM
CAN PACKAGING SYSTEM

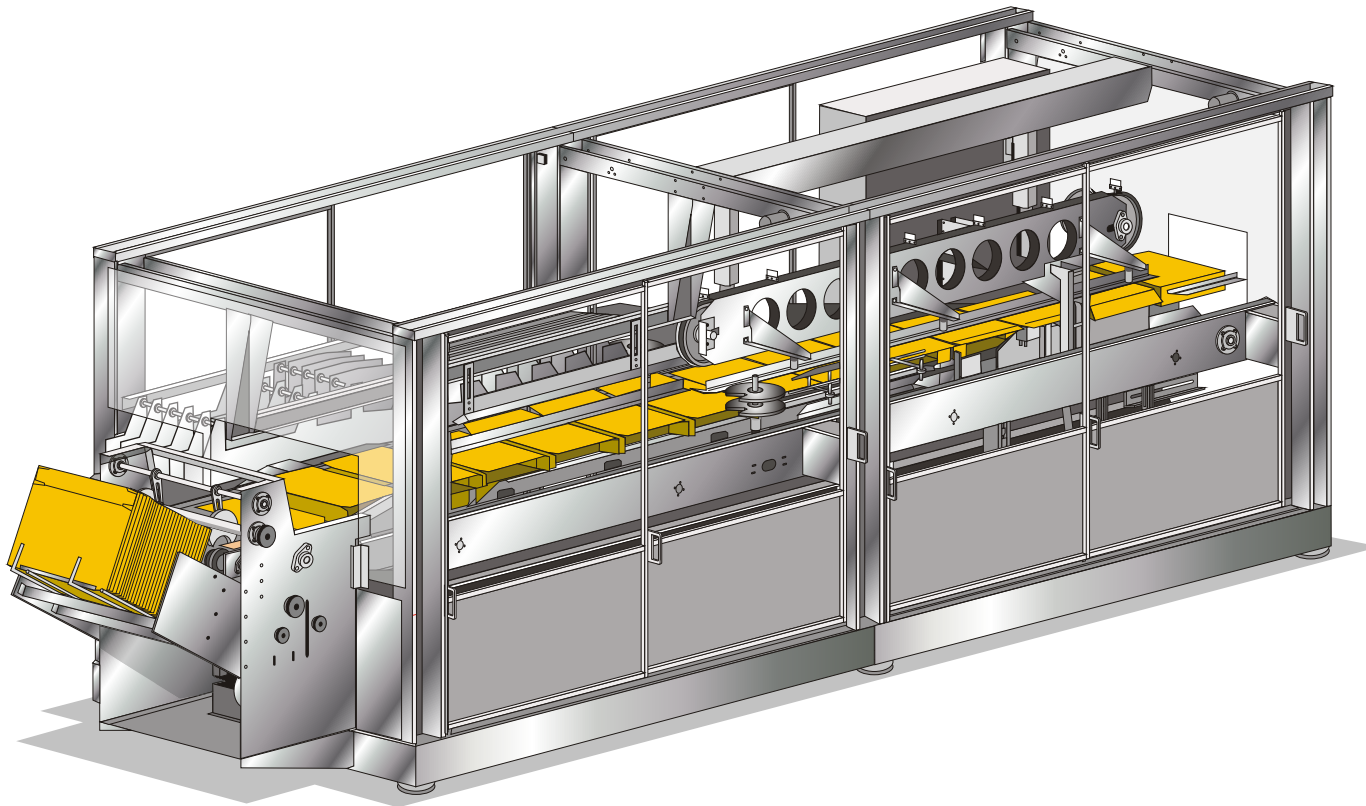

The Quikflex 200 system for fully-enclosed packaging is a ideal cost-effective solution for moderate speed requirements, new product introductions or trial market applications.



GRAPHIC PACKAGING
INTERNATIONAL, INC.

Quikflex[®] 200 Specifications

Machine Footprint

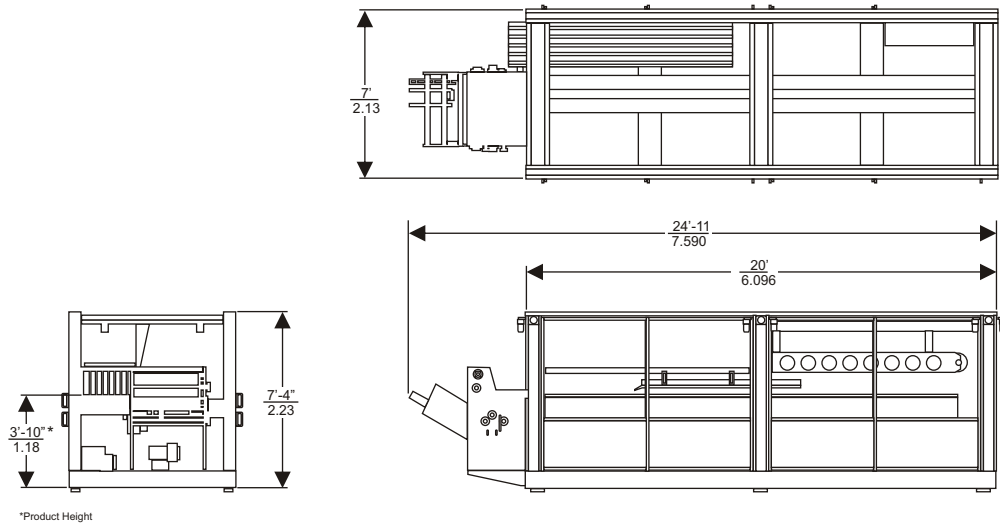

Key Features

Machine and package flexibility

Cans, glass and PET: the Quikflex 200 packages a wide range of product heights and dimensions into a wide variety of configurations and pack styles.

Moderate speed packaging

At sustained running speeds of 50 packs per minute, and surge speeds of 60 packs a minute, the Quikflex 200 is ideal for low speed or market trial applications.

Heavy duty, easy access construction

Our walk-in frame design and full height sliding guard doors provide total machine access for operator.

Machine Dimensions

25' long x 7' wide x 7'6" high
(7.6m x 2.1m x 2.3m)

Machine Weight

Approximately 10,000 lbs. (4,545 kg)

Speed Range

Sustained running speeds of 50 packs per minute and surge speeds of 60 packs per minute.

Electrical

460 volts, 3 phase, 60Hz or to customer specification.

Air Requirements

80 PSI, 11 CFM

Hot Melt

Melton C84HF

Construction

All Stainless Steel

Standard Package Styles

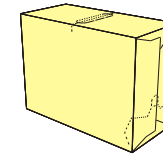

Square Corners

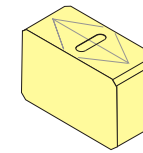

Beveled Corner

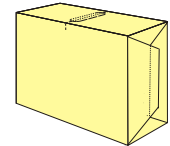

Overlap or Butt Flap

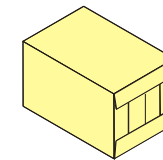

Economy Flap

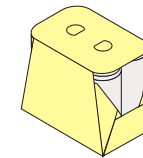

No Top Flap

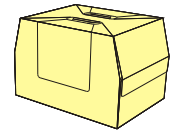

2 sided Taper Pack



Package Configuration

2x2 through 4x6 for most container sizes.

Product Ranges

Most round containers, typically 2" to 4" diameter.

Standard Features

- Segment wheel feeder for positive control
- Wedge metering for smooth product infeed
- Moving bed selector system for maximum product stability.



Graphic Packaging International, Inc.
814 Livingston Court
Marietta, Ga 30067
Phone (770) 644-3000 Fax (770) 644-2970
www.graphicpkg.com