

MARKSMAN™ 750 HS

High-Speed Can Wrap Packaging System

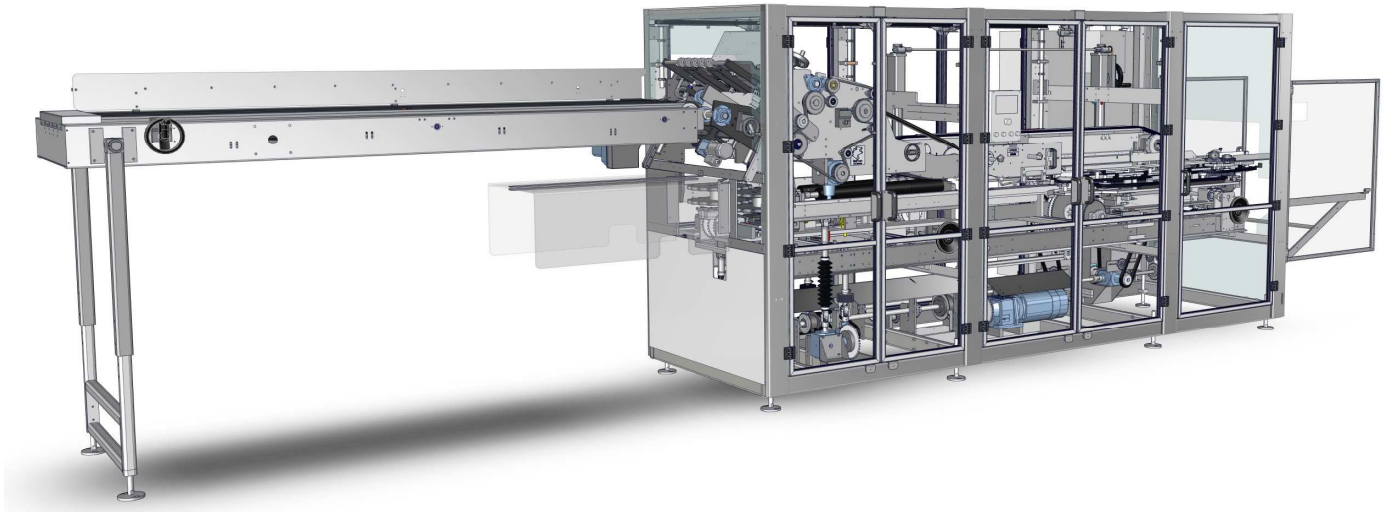

MARKSMAN™ 750 HS

Cans

The Marksman™750HS is a dedicated can machine, targeted for small multiple can packs of 2x2, 2x3 and 1x3 formats. The base design is capable of running multiple can heights and with appropriate change parts can run multiple can diameters. The package capability includes top and bottom gussets on dual lane packs. The machine benefits from a top speed of 300 packs per minute and a small footprint.

Machine Features

Standard

- Graphic Packaging standard lock
- Dual venturi vacuum generators
- Automatic oil system
- Automatic grease system
- 9 ft (3m) 5000 carton powered magazine
- Market proven segment wheel feeder with optimized geometry

Frame

- Stainless steel frame with corrosion resistant components

Guards

- Full height, clear hinged guard doors providing access to the machine functions for changeover and maintenance

Optional

- Powered magazine with capacity for 10,000 cartons
- Lock inspection w/wo pack reject

Specifications

Standard Machine Elevation

41 3/8" +/-2" (1050mm +/-50mm)

Machine Weight

Approx. 10,500lbs (4,800 kg)

Air Requirements

80psi - 8 CFM
(6 bar - 14 m³/h)

Electrical

400/460 VAC
50/60 Hz

Main Drive Motors

AC Gearmotor

Ancillary Equipment

Turner / Divider / Reject units

Changeover

No-tool changeovers are quick, simple and repeatable

Time

30 minutes (format change)
45 minutes (product / change)

Primary Container Size Ranges

2-piece beverage cans only

Diameter: 2.09" (53mm) to 2.6" (66mm)

Height: 3.46" (88mm) to 7.44" (189mm)

Pack Formats

Standard: 1x2, 1x3, 2x2, 2x3

Optional: 1x4, 1x5, 1x6, 2x4, 2x5, 2x6

MM750HS 12 1/2"

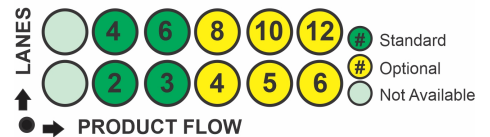

Pack Styles

- Top and bottom gussets for dual lane packs
- Straight wraps with wrap heel and crown apertures for single lane packs

Speed / Pitches

Operates at speeds up to:

Pitch	Line	Surge
10"	250ppm	300ppm
12.5"	200ppm	240ppm

Machine Footprint

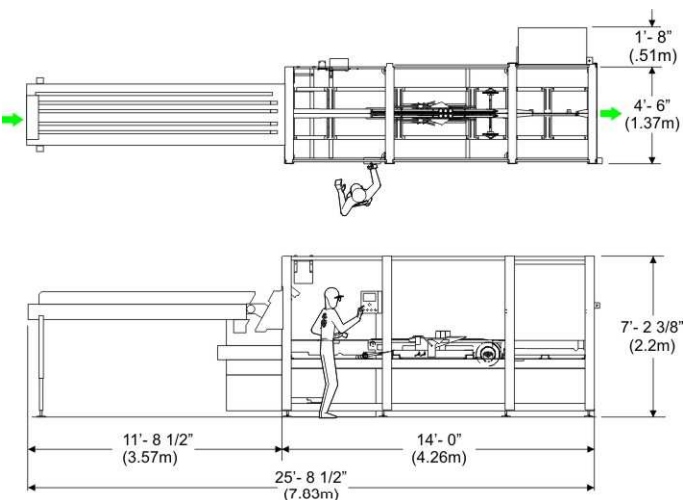

Graphic Packaging International
1500 Riveredge Parkway NW, #100
Atlanta, GA 30328
+1 (770) 240-7200

Please visit our website at
graphicpkg.com
for more information.

© Copyright 2023, Graphic Packaging International.
All rights reserved.